

Keysight Technologies N5172B/82B MXG Signal Generators Baseband Generator with Real-Time Capability Option 660 Upgrade Kit

Note: For the latest revision of this installation note, go to the following website:

<http://www.keysight.com/find/mxg>

NOTICE: This document contains references to Agilent Technologies. Agilent's former Test and Measurement business has become Keysight Technologies. For more information, go to www.keysight.com.

Installation Note

Part Number: N5180-90067

Published in USA
January 2015

Notice.

The information contained in this document is subject to change without notice.

Keysight Technologies makes no warranty of any kind with regard to this material, including but not limited to, the implied warranties of merchantability and fitness for a particular purpose.

Keysight Technologies shall not be liable for errors contained herein or for incidental or consequential damages in connection with the furnishing, performance, or use of this material.

Baseband Generator with Real Time Capability Option 660 Upgrade Kit

Products Affected:	N5172B and N5182B
Serial Numbers:	All
Options:	All
To Be Performed By:	(X) Keysight Technologies Service Center (X) Personnel Qualified by Keysight Technologies (X) Technical Customer
Estimated Installation Time:	1.5 hours
Estimated Verification Time:	0.75 hours

Introduction

This upgrade kit provides the necessary installation instructions and hardware for updating an MXG in the field with the Real Time BBG Option 660 assembly.

This upgrade kit requires firmware revision > B.01.50.

NOTE This upgrade kit contains hardware and an option activation license. A PC or UNIX computer with LAN access is also required.

Installation includes completing the following major steps, in the order given.

1. Check signal generation operation.
2. Run the self tests.
3. Install the latest revision of firmware.
4. Remove the outer cover.
5. Remove the inner top cover.
6. Install the new hardware and cables.
7. Replace the inner top cover.
8. Replace the outer cover.
9. Redeem and install the Option 660 license.
10. Run the I/Q calibration.
11. Run the self test.

Installation Kit Parts List

Quantity	Description	Part Number
1	Real Time Deck Assembly	N5180-60182
1	A8 Real Time BBG Jumper Board	N5180-60197
3	Cable Clips	1400-3357
6	Screw, machine, Pan head, Torx T-10 M3 x 0.5, 12 mm	0515-0664
5	Screw, machine, Pan head, Torx T-10, M3 x 0.5, 8 mm	0515-0372
1	Tie-wrap	1400-0249
1	Media Binder ^a	5010-7769
1	Installation Note	N5180-90065

a. The Entitlement Certificate (included in the binder) requires redemption and installation of the license key to enable Option 660 in the MXG option string.

Tools Required

- TORX T-10 driver
- TORX T-20 driver
- Torque Wrench (9-21 in-lb.)
- Long-nose pliers

Safety Considerations

WARNING Before you disassemble the signal generator, turn the power switch off and unplug the power cord. Failure to unplug the signal generator can result in personal injury.

CAUTION Electrostatic discharge (ESD) can damage or destroy electronic components. All work on electronic assemblies should be performed at a static-safe workstation.

Check Signal Generator Operation

Use the following procedure to confirm that the signal generator powers up and that the internal check does not identify any errors. The internal check evaluates the operation of the signal generator and returns an error message if it detects a problem. Self test will confirm that the signal generator is operating properly or isolate detected problems to a specific faulty assembly.

1. Turn on the signal generator and let it warm up for at least five minutes.
2. Check to see if the ERR annunciator is on. If it is on, proceed with the following steps:
 - a. Review the error message in the error queue. Press **Error**. The first error message in the error queue appears in the display text area. (Refer to the signal generator error messages document for information about each error message.)
 - b. Resolve all of the errors and then press **Clear Error Queue(s)**.

Run the Self Tests

The self test is a series of internal tests of signal generator functions. Run the complete self tests when initially setting up a signal generator, after an assembly repair, or to verify signal generator performance. Also run self test prior to performing manual or automated Performance Verification tests. The self test will confirm the signal generator is operating properly or isolate problems to a specific faulty assembly.

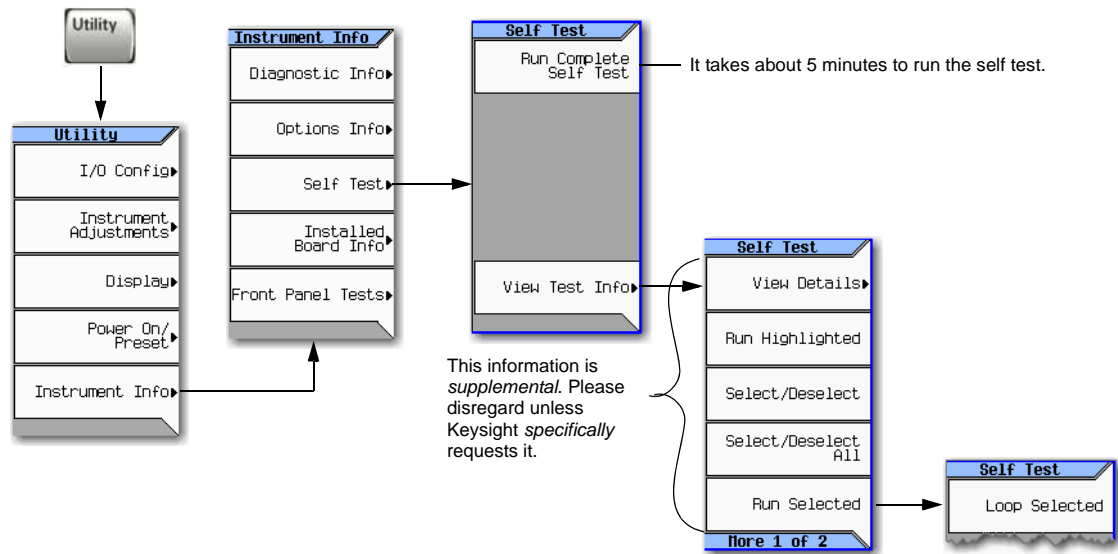

Install the Latest Revision of Firmware

Use the firmware CD provided or go to the Keysight web, <http://www.keysight.com/find/mxg>, to obtain the most recent firmware revision. Follow the instructions provided with the firmware to install the latest firmware onto the MXG.

Remove the Outer Cover

Tools Required

- T-20 driver

Removal Procedure

Refer to **Figure 1** for this procedure.

1. Disconnect the power cord.
2. Using the T-20 driver, loosen the two screws (1) and remove the strap handle (2).
3. Using the T-20 driver, remove the two hole plugs (not shown in photo) from the opposite side of the instrument.
4. Using the T-20 driver, remove the center screws from the four rear-panel feet (3).
5. Remove the four bottom feet (4) from the cover by lifting the tab and sliding the foot toward the tab.
6. Place the signal generator on its side.
7. Place one hand on the front panel, use the other hand to lift the rear of the signal generator and slide the outer cover (5) off to remove it from the frame.

CAUTION The RF connector can be easily damaged. Use extreme caution to not damage the RF connector when lifting the rear of the signal generator.

Figure 1

Outer Cover Removal

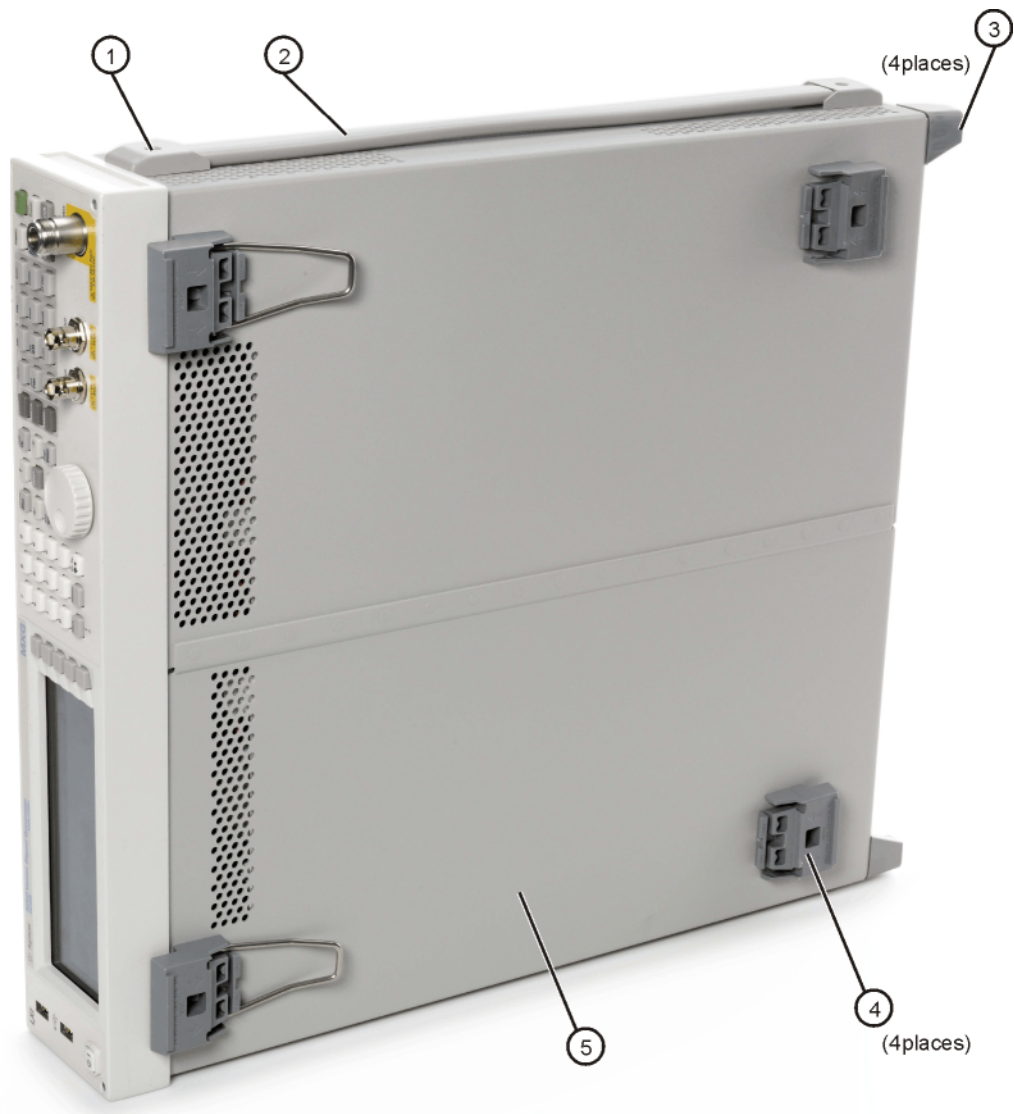

external

Remove the Inner Top Cover

Tools Required

- T-10 driver

Removal Procedure

Refer to Figure 2 for this procedure.

1. Place the signal generator flat with the front-panel facing you. (The power cord should have been disconnected in the previous procedure and the outer cover removed.)
2. Using the T-10 driver, remove the nine flat-top screws (1) from the inner top cover (2).
3. Using the T-10 driver, remove the screw (3) from the rear panel.
4. Remove the inner top cover.

Figure 2

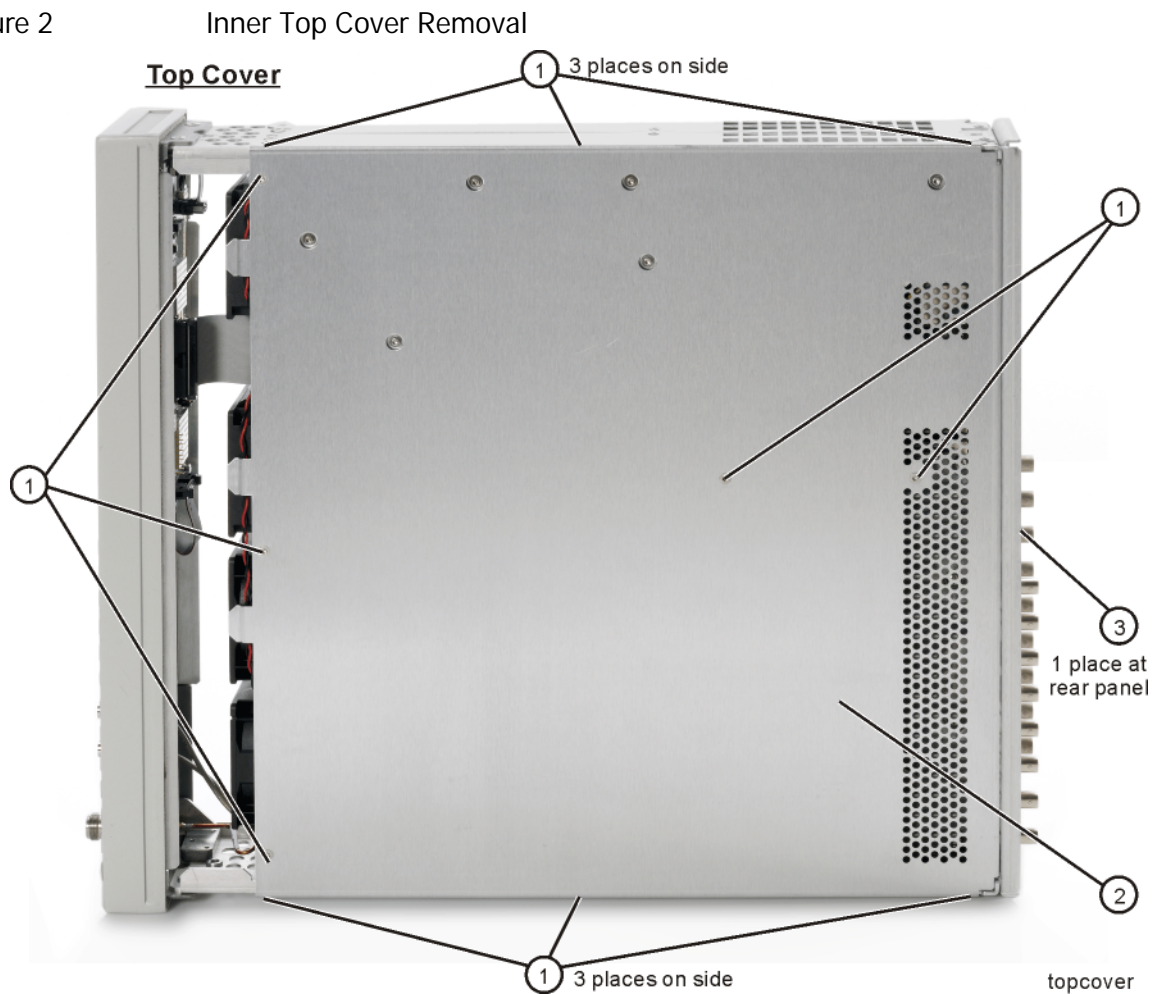

Install the New Hardware and Cables

1. Refer to Figure 3. Remove the plate (1) from the power supply (2). Discard the plate and screws.

Figure 3 Power Supply Plate

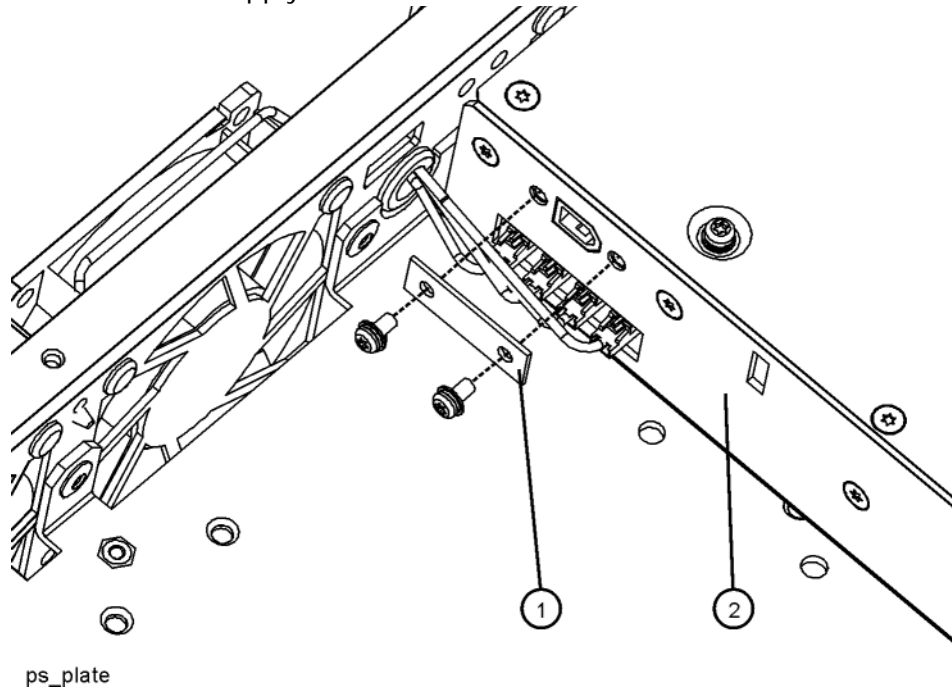

2. Refer to Figure 4. Remove W4 and W5 from the A2 Vector BBG assembly. Also remove the cable clip and clean off any residual adhesive.

Figure 4 W4 and W5 Removal

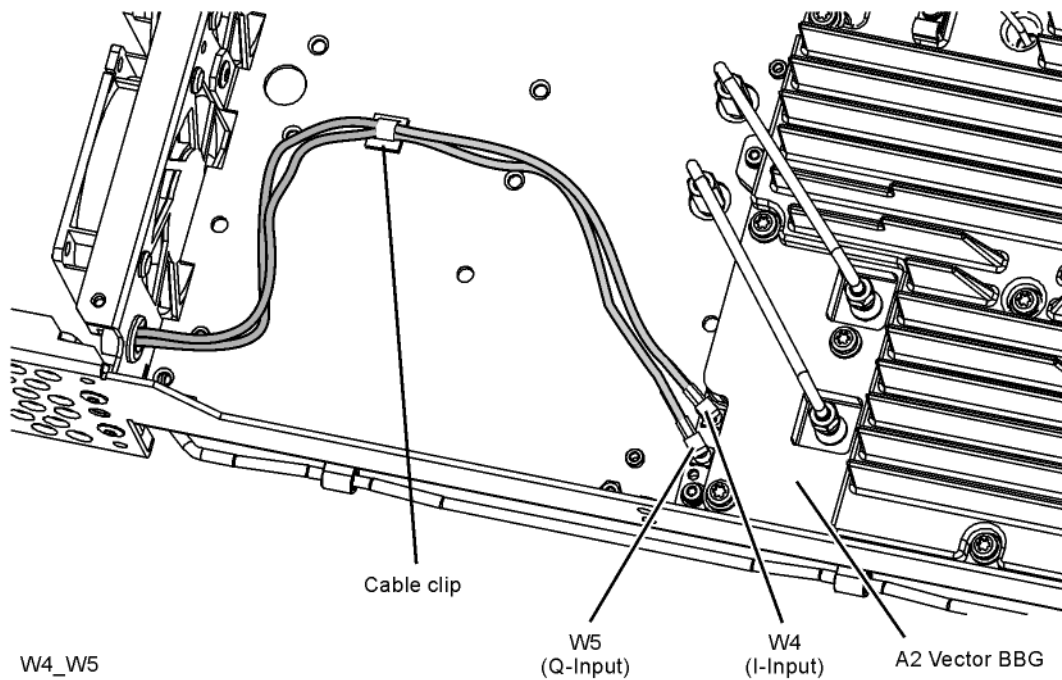

3. Figure 5 shows the Real Time BBG assembly as shipped. Place the Real Time BBG assembly into the chassis.
Hand start the six screws (1) (0515-0664) but leave loose at this time.
Figure 10 shows the assembly completely installed in the chassis.

Figure 5 Real Time BBG Assembly Installation

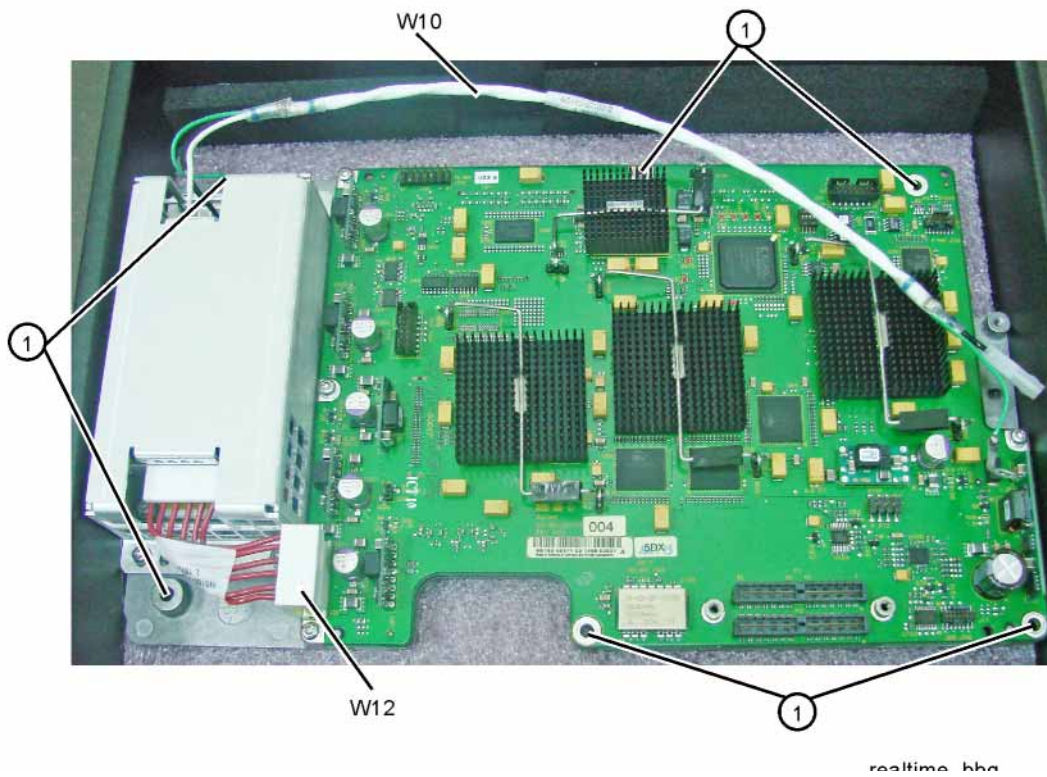

4. Refer to Figure 6 Align the A8 Real Time Jumper board (1) on the connectors on both the A7 Real Time BBG assembly and the A2 Vector BBG assembly. Install the four screws (2) (0515-0372). Torque to 9 in-lbs.

Figure 6 Real Time BBG Jumper Board Installation

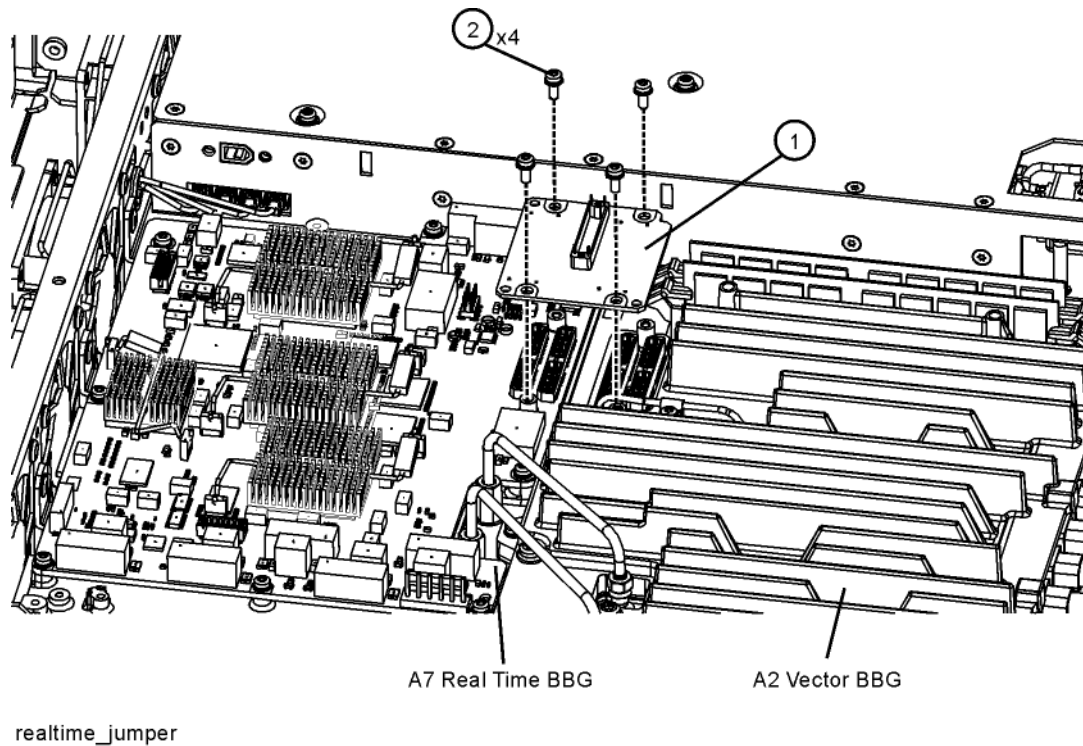

5. Refer to Figure 5 Now tighten and torque the six screws (1) (0515-0664) to 9 in-lbs.

6. Refer to Figure 7 Install the three cable clips (1).

Figure 7 Cable Clip Installation

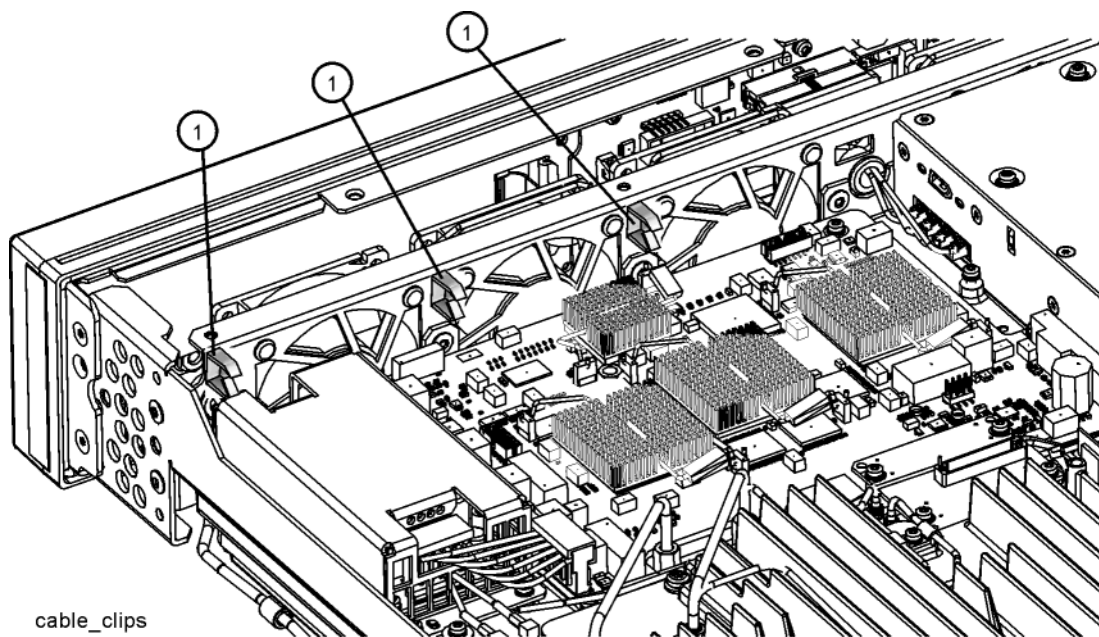

7. Refer to Figure 8 Plug W10 into the A1 Power Supply. Secure the grounding wire with a 0515-0372 screw. Torque to 9 in-lbs. Place W10 into the cable clips and tie-wrap to the fan cables.

CAUTION Be sure that the rigid part of the grounding wire does not touch the pc board.

Figure 8 W10 Installation

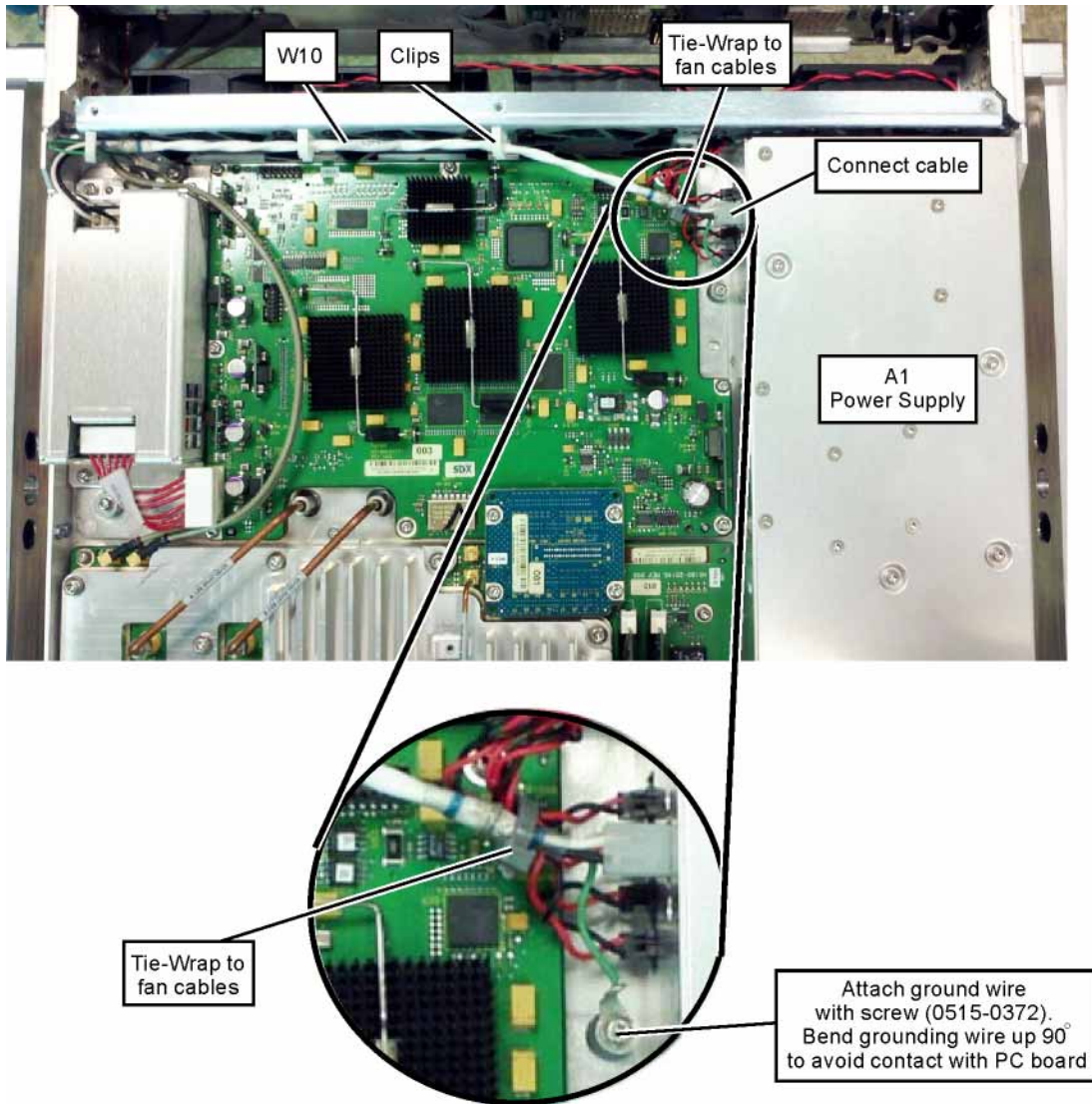

8. Refer to Figure 9 Route cables W4 and W5 as shown, and reconnect them to the A2 Vector BBG assembly. Figure 10 shows the fully installed assembly in the chassis.

Figure 9 W4 and W5 Cable Routing

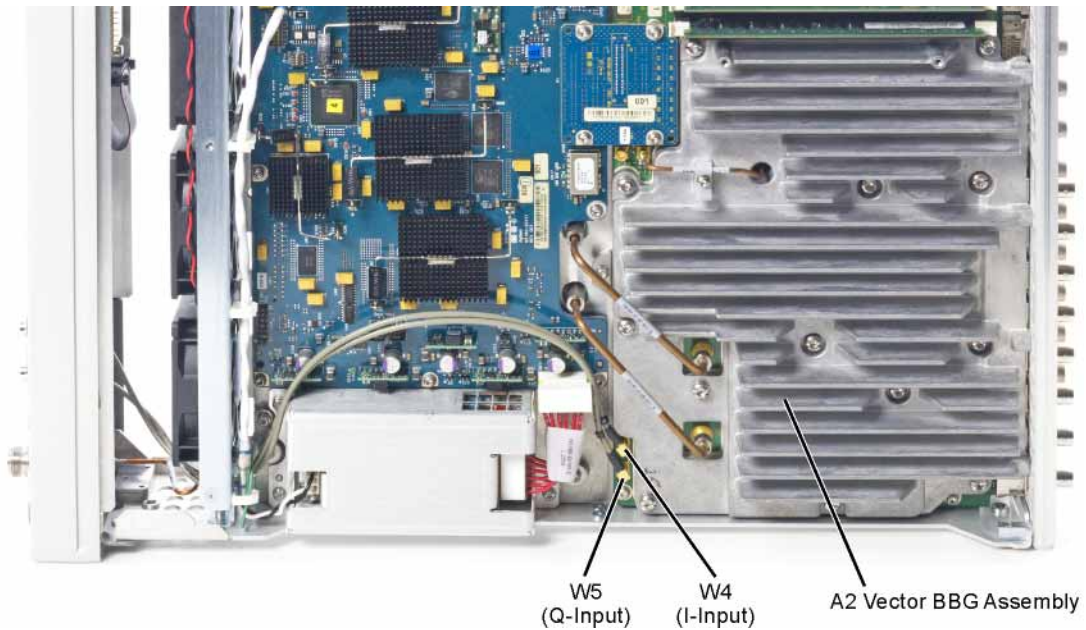
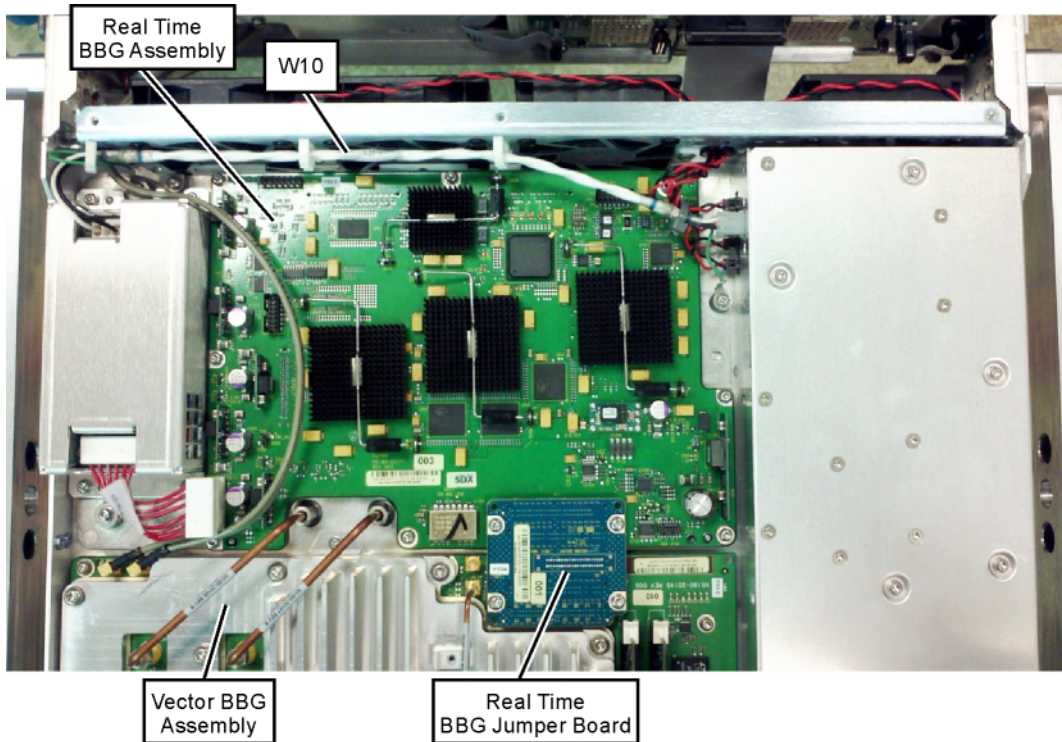

Figure 10 Real Time BBG Assembly in Chassis



Replace the Inner Top Cover

1. Reverse the order of the removal procedures.
2. Torque all screws to 9 in-lbs.

Replace the Outer Cover

1. Reverse the order of the removal procedures.

CAUTION When sliding the outer cover back on the signal generator, keep your fingers away from the back of the front panel. They can get pinched.

2. Torque all screws to 21 in-lbs.

Redeem and Install the Option 660 License

Redeem and install the Option 660 license key by following the instructions provided on the Entitlement Certificate.

Run the I/Q Calibration

When you perform an I/Q calibration, that calibration data takes precedence over the factory-supplied calibration data. The calibration routines improves performance that may degrade over time or due to temperature changes.

Press I/Q > I/Q Calibration > Calibration Type Full

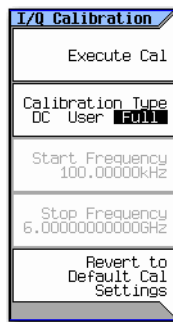

Run the Self Test

The self test is a series of internal tests of signal generator functions. Run the complete self test when initially setting up a signal generator, after an assembly repair, or to verify signal generator performance. Also run self test prior to performing manual or automated Performance Verification tests. The self test will confirm the signal generator is operating properly or isolate problems to a specific faulty assembly.

